

The USB add-on card makes your NUE-PSK Digital Modem more flexible and useful with its ability to record the QSO text (for both receive and transmit) to a USB flash memory stick for archival and remote printing. The USB card also provides a serial connection to a PC, and a real-time clock/calendar function (RTCC) to display time and date on the modem LCD and timestamp the QSOs in REC mode. The latest modem software contains the keyboard commands used for controlling the USB card functions, plus a comprehensive set of text editing commands. The USB card fits into the existing modem enclosure with minimal mods; a replacement bottom chassis with pre-drilled holes for the connectors is optionally available.

→ See full details online at <http://www.nue-psk/usb>

Designator	QTY	Description
C2, C12	2	Capacitor, SMD, 0805, 0.1 uF
C4, C10	2	Capacitor, SMD, 0805, 0.01 uF
C11	1	Capacitor, SMD, 0805, 0.001 uF
C6, C7, C13, C14	4	Capacitor, SMD, 0805, 47 pF
C8, C9	2	Capacitor, SMD, 0805, 68 pF
C1, C3	2	Capacitor, SMD, 1.0 uF
R5, R6, R10, R11	4	Resistor, SMD, 0805, 47K ohms
R1, R2, R3, R4	4	Resistor, SMD, 0805, 27 ohms
R9	1	Resistor, SMD, 0805, 10K ohms
R7	1	Resistor, SMD, 0805, 180 ohms
R25, R26	2	Resistor, SMD, 0805, 330 ohms
R12, R13	2	Resistor, SMD, 0805, 100K ohms
R14, R15	2	Resistor, SMD, 0805, 1K ohms
P2	1	USB connector, Type A
P1	1	USB connector, Type B
J1	1	SIP receptical, 0.1", 1x4, 90-deg
J2	1	SIP receptical, 0.1", 1x3
W1	1	Ribbon cable, 3-wire, 4"
P3	1	Pinheader, 1x3, 0.1", R/A
LED1, LED2	2	LED, 90-deg, green
U1	1	Vinculum VNC1L-1A, LQFP-48
U2	1	Voltage regulator, 3.3V, LP2950 (TO-92)
X1	1	Crystal, 12.0 MHz, 20 pF
PCB	1	PC Board
	1	Desolder braid, 6"
	2	Spacer, nylon, hex tapped, 4-40x1/4" (PCB)
	4	Machine screw, pan slotted, #4-40x3/16"
RTCC		
U4	1	CMOS switch, FST3126
U3	1	PIC16F688, DIP-14
J3	1	IC socket, 14-pin DIP
J4	1	SIP socket, 1x5
X1	1	Crystal, 32.768 kHz, cylinder
C5	1	Capacitor, SMD, 0805, 0.1 uF
C15, C16	2	Capacitor, SMD, 0805, 22 pF
R16	1	Resistor, SMD, 0805, 1K ohms
R17	1	Resistor, 22K ohms, 1/8W axial
R18	1	Resistor, 22K ohms, 1/8W axial
BATT	1	Battery, 3V



Photo 2: Adding 5V to P4
(See Assy step 8)

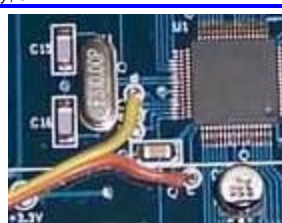
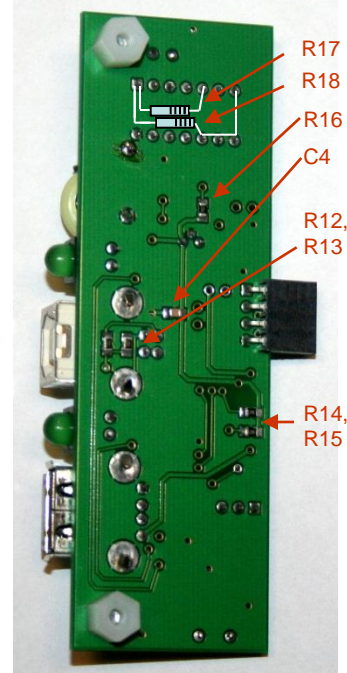
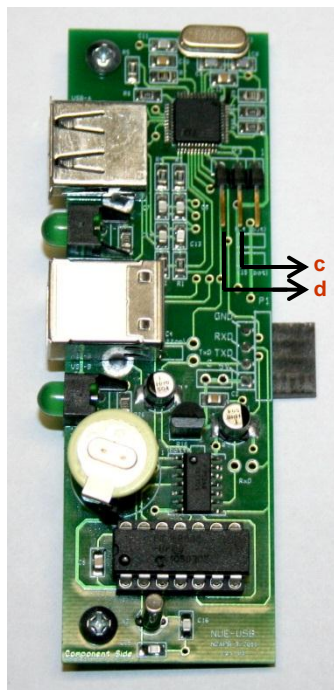

Photo 1: Control Cable
(See Assy step 7.)



Assembly Instructions

- 1) Attach U1 and U4. Use care to ensure they are carefully aligned. Use desolder braid (supplied) to remove excess solder between pins, if needed.
- 2) Attach all parts from the SMT card. C4, R12, R13, R14, R15 and R16 should be mounted on bottom of board. (Their outlines are shown on top.)
- 3) Attach crystals X1 and X2 slightly elevated so they touch no other parts.
- 4) Attach all remaining parts. J1 mounts on bottom side, and P3 mounts on top. Check photos for proper placement. Ensure that P1, P2, LED1 and LED2 are mounted flat and straight.
- 5) J4 is used as a socket for the battery. Snip off the inner three pins, leaving the outer two, and solder it in place at the battery position.
- 6) Attach two nylon standoffs with screws.
- 7) Create the 2-wire Control cable with ribbon cable and J2. Solder one end of cable to J2. On modem board, remove screws and lift up LCD. Solder two wires on other end of cable to points 'c' and 'd' on the modem board at lower left area of U1 (See photo 1). This cable will plug into P3 when USB board is plugged in. The wire coming from P3 pin 3 (the left, or innermost pin of P3) goes to pad 'd' on the modem board. The wire from P3 pin 2 goes to modem pad 'c'. The third (outermost) position of P3 is unused.
- 8) Add 5V jumper on modem board at Field Programming port P4. First cut the 'x' trace connecting the two pads near the lower-left LCD standoff. (Make sure this 3.3V trace is thoroughly cut.) Next add a short jumper from the leftmost 'X' pad down to the pad above the Select pushbutton. This jumper will supply 5V to the USB card. (See photo 2.)
- 9) Add pull-up resistor R17 between U3 pins 1 and 5 on the bottom of pcb
- 10) Add pull-up resistor R18 between U3 pin 1 and U3 pins 7, 8, 9 and 10.
- 11) Insert the programmed PIC controller U3 into the IC socket.
- 12) Battery preparation & insertion: Put slight bends in battery leads to form small 'v' (helps to hold in socket). Insert the battery with the top tab (positive) in the hole closer to U3. The battery should measure between 2.7V and 3.1V. Using a clip lead, tap U3 pin 4 to ground to reset the PIC before applying power to the modem for the first time (only).

Final Assembly

- 1) Use template from website to make holes in existing bottom chassis for USB connectors and LEDs, or use the optionally-purchased pre-drilled chassis.
- 2) Plug in the USB card to the Field Programming port P4 along the modem board's left edge and attach the Control cable to P3. Ensure that the wire from pin 1 goes to the modem pad 'a'.
- 3) Insert board assembly to new/modified chassis and screw into place. (Proper clearance for modem board controls can be achieved by biasing board to lower left while tightening top and bottom screws.)

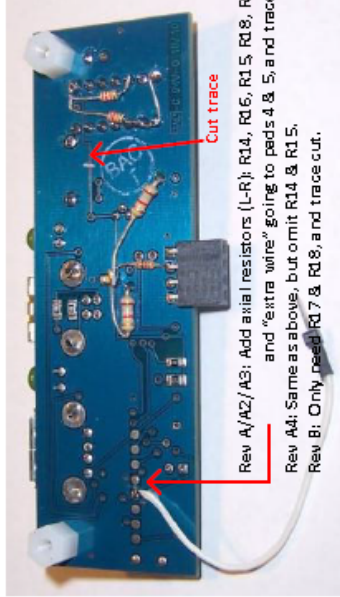

Rev A/A2/A3: Add axial resistors (L-R): R14, R16, R15, R18, R17) and "extra wire" going to pads 4 & 5, and trace cut.
 Rev A4: Same as above, but omit R14 & R15.
 Rev B: Only need R17 & R18, and trace cut.

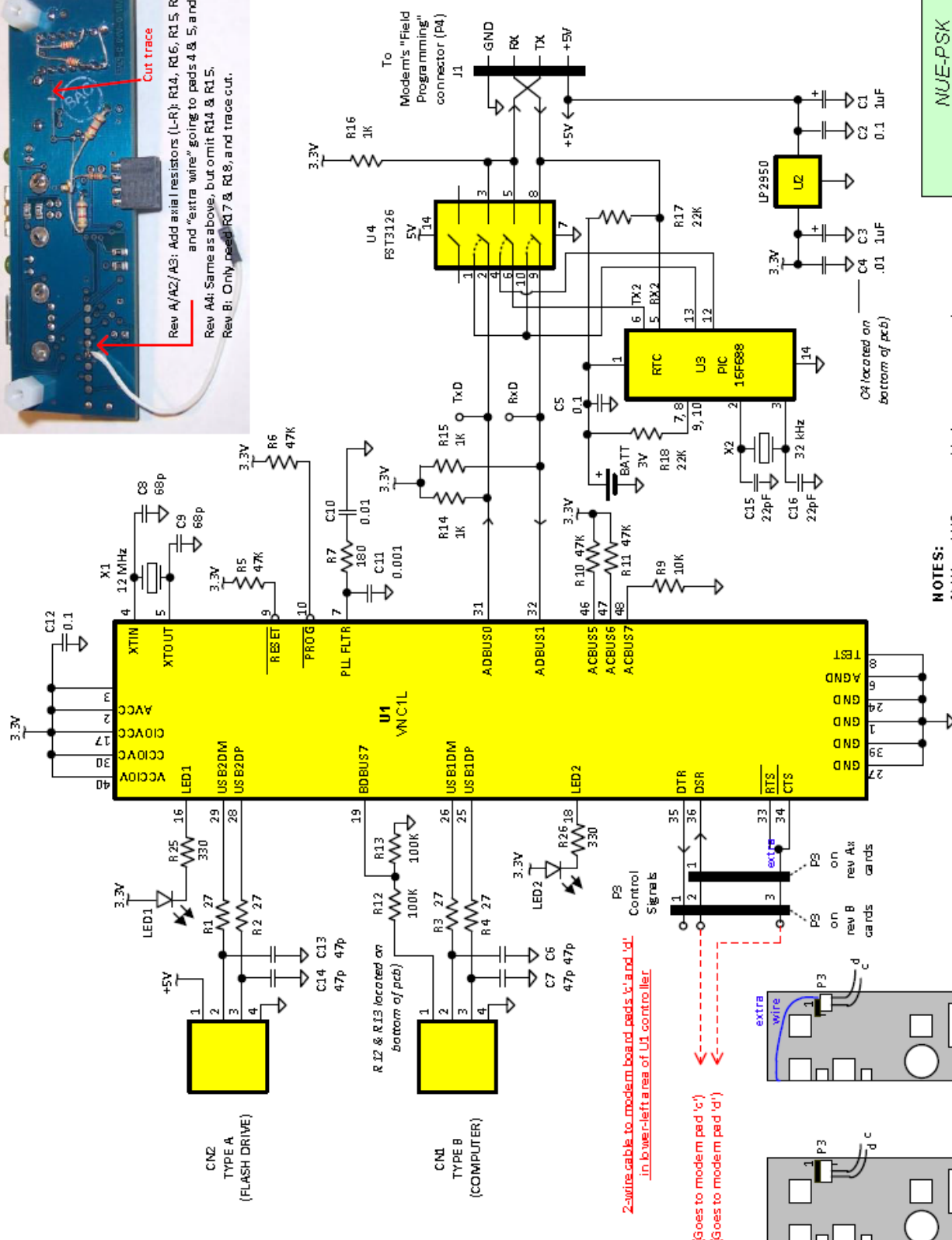

NOTES:
 1) U1 and U3 are provided pre-programmed.
 2) See mods in photo above for different version cards

NUJE-PSK
USB Option
 Rev B11 N2 APB 12/15/2011

2-wire cable to modem board pads 'c' and 'd' in lower-left area of U1 controller

(Goes to modem pad 'c')
 (Goes to modem pad 'd')

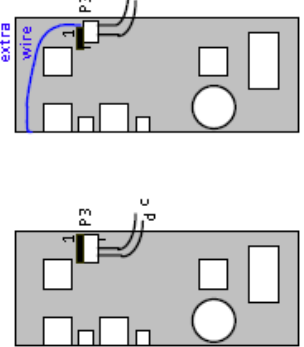

Rev A, A2, A3, A4
 Rev B