

The USB add-on card makes your NUE-PSK Digital Modem more flexible and useful with its ability to record QSO receive and transmit text to a USB flash memory stick for archival and remote printing. The USB card also provides a serial connection to a PC, a port for a USB printer, and a real-time clock/calendar function (RTCC) to timestamp QSOs. The updated v1.30 modem software contains the new keyboard commands for controlling the USB card functions, plus an improved and consistent set of text editing commands. The USB card fits into the existing modem enclosure with minimal mods, and a replacement bottom chassis is available with pre-drilled holes for the connectors.

**NOTE 1:** Only the Record function is currently supported in software. Updates will come soon to allow printing and PC connections. RTCC parts are not provided in this kit.

**NOTE 2:** This kit requires the builder to program U1. See the section at the bottom of the page for the easy steps.

**NOTE 3:** A full manual is available at [www.nue-psk.com/usb](http://www.nue-psk.com/usb)

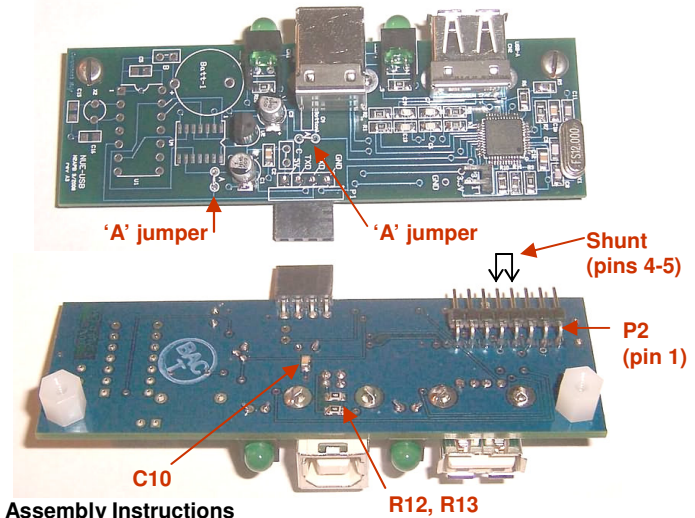

Designator	QTY	Description
<b>SMT Card</b>		
C2, C12	2	Capacitor, SMD, 0805, 0.1 uF
C4, C10	2	Capacitor, SMD, 0805, 0.01 uF
C11	1	Capacitor, SMD, 0805, 0.001 uF
C6, C7, C13, C14	4	Capacitor, SMD, 0805, 47 pF
C8, C9	2	Capacitor, SMD, 0805, 68 pF
R5, R6, R10, R11	4	Resistor, SMD 0805, 47K ohms
R1, R2, R3, R4	4	Resistor, SMD 0805, 27 ohms
R9	1	Resistor, SMD 0805, 10K ohms
R7	1	Resistor, SMD 0805, 180 ohms
R25, R26	2	Resistor, SMD 0805, 330 ohms
R12, R13	2	Resistor, SMD 0805, 100K ohms
<b>Bagged Parts</b>		
C1, C3	2	Capacitor, SMD, 1.0 uF
P2	1	USB connector, Type A
P1	1	USB connector, Type B
J1	1	SIP receptacle, 0.1", 1x4, 90-deg
P2	1	Pinheader, 1x8, 90-deg
P3	1	Pinheader, 1x2. 0.1", 90-deg
LED1, LED2	2	LED, 90-deg, green
U1	1	Vinculum VNC1L-1A, LQFP-48
U2	1	Voltage regulator, 3.3V, LP2950 (TO-92)
X1	1	Crystal, 12.0 MHZ
PCB	1	PC Board
	2	Spacer, nylon, hex tapped, 4-40x1/4" (PCB)
	4	Machine screw, pan slotted, #4-40x3/16"
	1	Solder braid, 6" (assist w ith attaching U1)
<b>Connector for programming USB chip:</b>		
	1	SIP receptacle, 0.1", 1x8
<b>Extra signal cable to modem board:</b>		
J2	1	SIP receptacle, 0.1", 1x2
	1	Ribon cable, 2-conductor, 6"

### Assembly Instructions

- 1) Attach U1. Use care to ensure it is carefully aligned. Use desolder braid (supplied) to remove excess solder between pins.
- 2) Attach all parts from SMT card. C10, R12 and R13 are mounted on bottom of board (outlines shown on top.)
- 3) Attach crystal X1 slightly elevated so it touches no other parts.
- 4) Attach all remaining parts. J1 mounts on bottom side, and P3 mounts on top. Check photos for proper placement. Ensure that P1, P2, LED1 and LED2 are mounted flat and straight.
- 5) Mount programming header P2 on bottom side by soldering short 90-deg end of connector to the 8 surface mount pads. Add solder to first pad then solder first pin while holding connector parallel to board, pointing to same side as J1. Solder remaining pins to surface pads.
- 6) Add the two 'A' jumpers. Using sharp blade, scrape solder mask off bottom side holes of each set of jumper pads to expose copper, then insert bare wire across pads from top and solder on bottom pads.
- 7) Attach two nylon standoffs with screws.
- 8) Create 2-wire "extra signals" cable with ribbon cable and J2. Solder one end of wires to J2 and note color going to pin 1 on P3. (Pin 1 is closest to board edge - violet wire in photo above.) On modem board, remove screws and lift up LCD. Solder two wires on other end of cable to points 'a' and 'c' on the modem board at lower left area of U1.) This cable will plug into P3 when USB board is plugged in. P3 pin 1 goes to pad 'c'. (See photo 1.)
- 9) Add 5V jumper on modem board at Field Programming port P4. First cut the 'x' trace connecting the two pades near the lower-left LCD standoff. (Make sure this 3.3V trace is thoroughly cut.) Next add a short jumper from the leftmost 'X' pad down to the pad above the Select pushbutton. This jumper will supply 5V to the USB card. (See photo 2.)

### Program the USB chip

- 1) Make the cable to program U1 via your PC serial port by using the wiring diagram shown on schematic to connect the 8-position SIP connector to your USB or RS-232 serial port adapter.
- 2) Download two files from [www.nue-psk.com](http://www.nue-psk.com) (vprog.com and vdps.rom). With the serial port connected to the USB card, run vprog and specify the vdps.rom file to quickly program the USB chip.
- 3) After removing programming cable, attach shunt (jumper) to programming header P2 at pins 4 (CTS) and 5 (RTS).

### Final Assembly

- 1) Use template from website to make holes in existing bottom chassis for USB connectors and LEDs, or use the optional pre-drilled chassis.
- 2) Plug in the usb card to the Field Programming port P4 along the modem board's left edge and attach the Extra Signal jumper to P3.
- 3) Insert board assembly to new/modified chassis and screw into place. (Proper clearance for modem board controls can be achieved by biasing board to lower left while tightening top and bottom screws.)

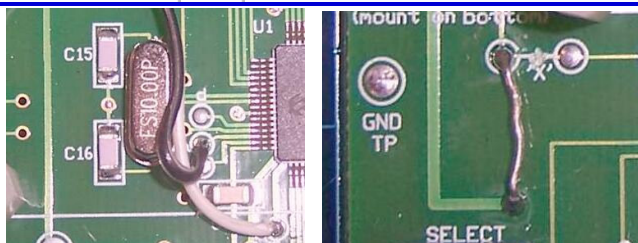
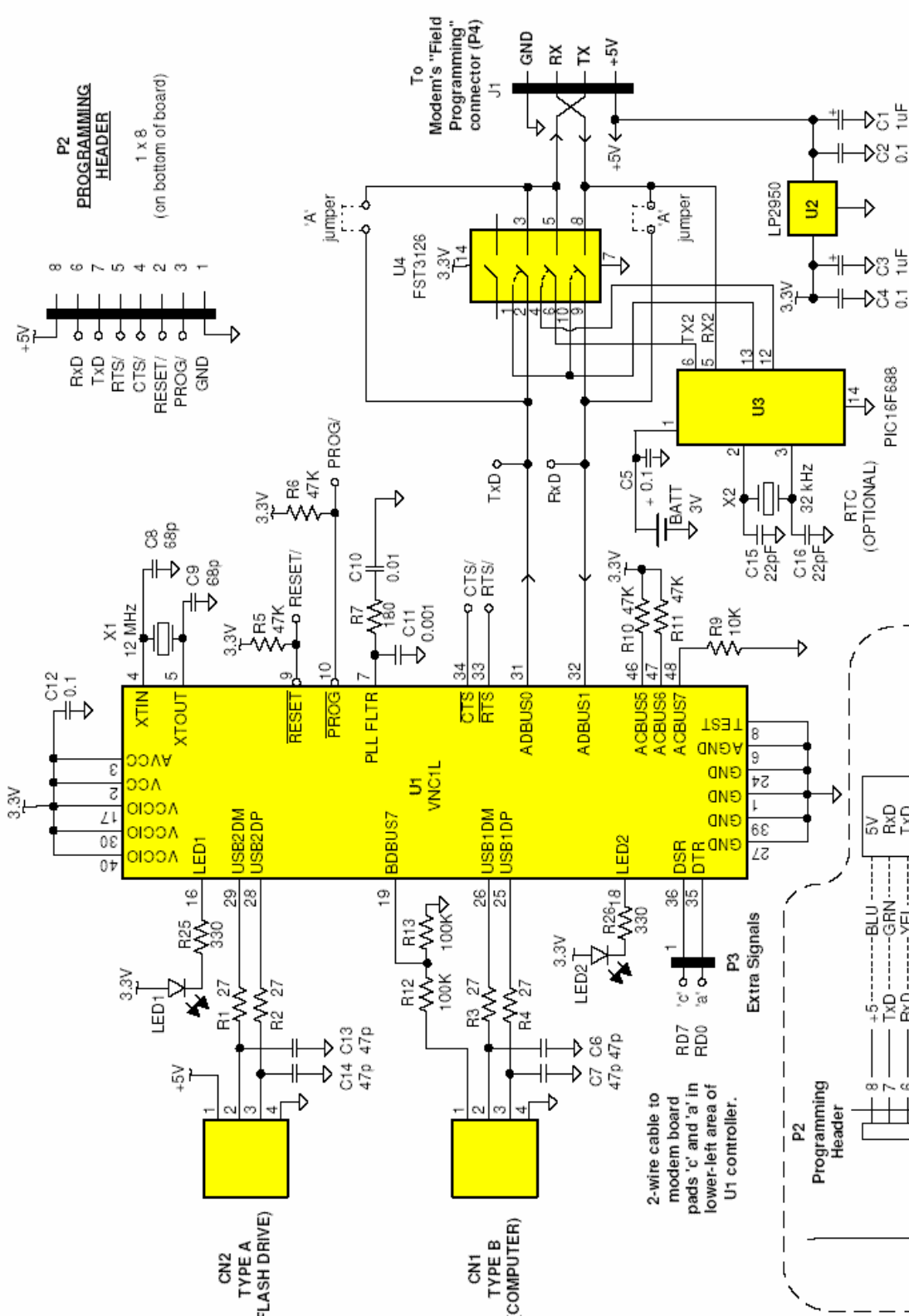

Photo 1: "Extra Signals cable"  
(See Assy step 8)

Photo 2: Adding 5V to P4  
(See Assy step 9)



- NOTES:**
- 1) Real-time Clock Calendar (RTCC) components not supplied in kit (U3, U4, C5, C15, X2, BATT)
  - 2) A jumpers necessary when RTCC components not in place.
  - 3) U1 must be programmed before use. See manual for simple procedure.

**NUJ-PSK**  
**USB Option**  
 NZAPB 10/01/2008

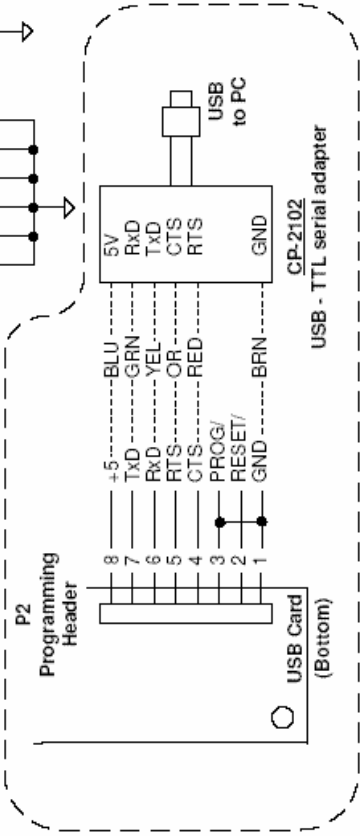

2-wire cable to modem board pads 'c' and 'a' in lower-left area of U1 controller.